

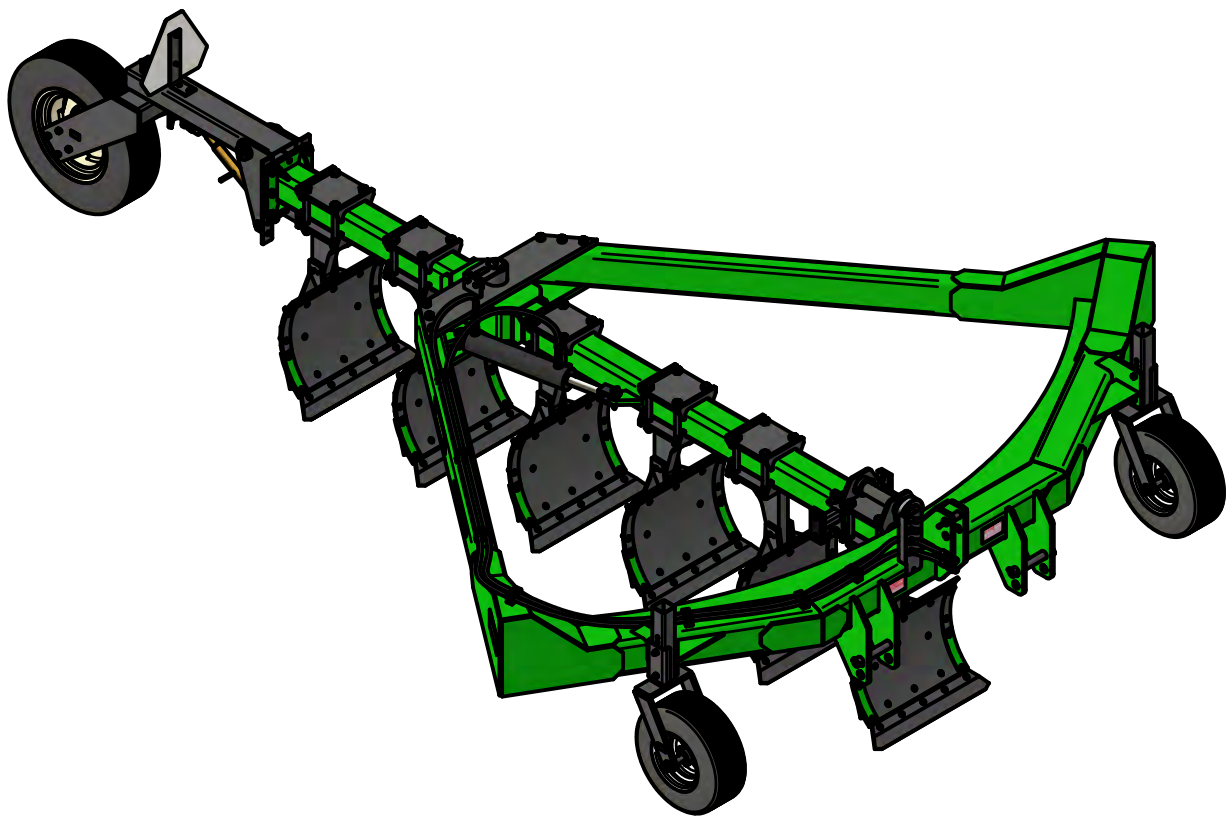

6306 ON LAND PLOW

PARTS MANUAL



216 INDUSTRIAL BLVD., RAMP 2
BAINBRIDGE, GA 39817
(229) 246-0350
www.harrellag.com

63-PM-002-01

TABLE OF CONTENTS

70-002-63.....	6306 - 6 BOTTOM PLOW.....	4
72-001-63.....	FRONT BOTTOM KIT.....	6
72-002-63.....	FORWARD INTERMEDIATE BOTTOM KIT.....	8
72-003-63.....	REVERSE INTERMEDIATE BOTTOM KIT.....	10
72-004-63.....	REVERSE REAR BOTTOM KIT.....	12
72-005-63.....	FORWARD REAR BOTTOM KIT.....	14
83-001-63.....	FRAME.....	16
83-003-63.....	TOOL BAR.....	18
83-003-36.....	MOLD BOARD w/SHORT SLIDES.....	20
83-206-36.....	MOLD BOARD w/LONG SLIDES.....	22
83-004-63.....	REAR GAUGE WHEEL BUNDLE.....	24
84-214-36.....	TOOL BAR PIVOT ROLLER.....	26
84-1000-63.....	REAR GAUGE WHEEL ASSEMBLY.....	28
84-003-63.....	FRONT GAUGE WHEEL.....	30
84-1006-63.....	TOOL BAR STOP.....	32
84-1007-63.....	FRONT SHANK ASSEMBLY.....	34
84-1014-63.....	FRONT GAUGE WHEEL HUB.....	36
79-047-36.....	HYDRAULIC CYLINDER/SEALS.....	38
MISC PARTS.....		39

6306 - 6 BOTTOM

70-002-63

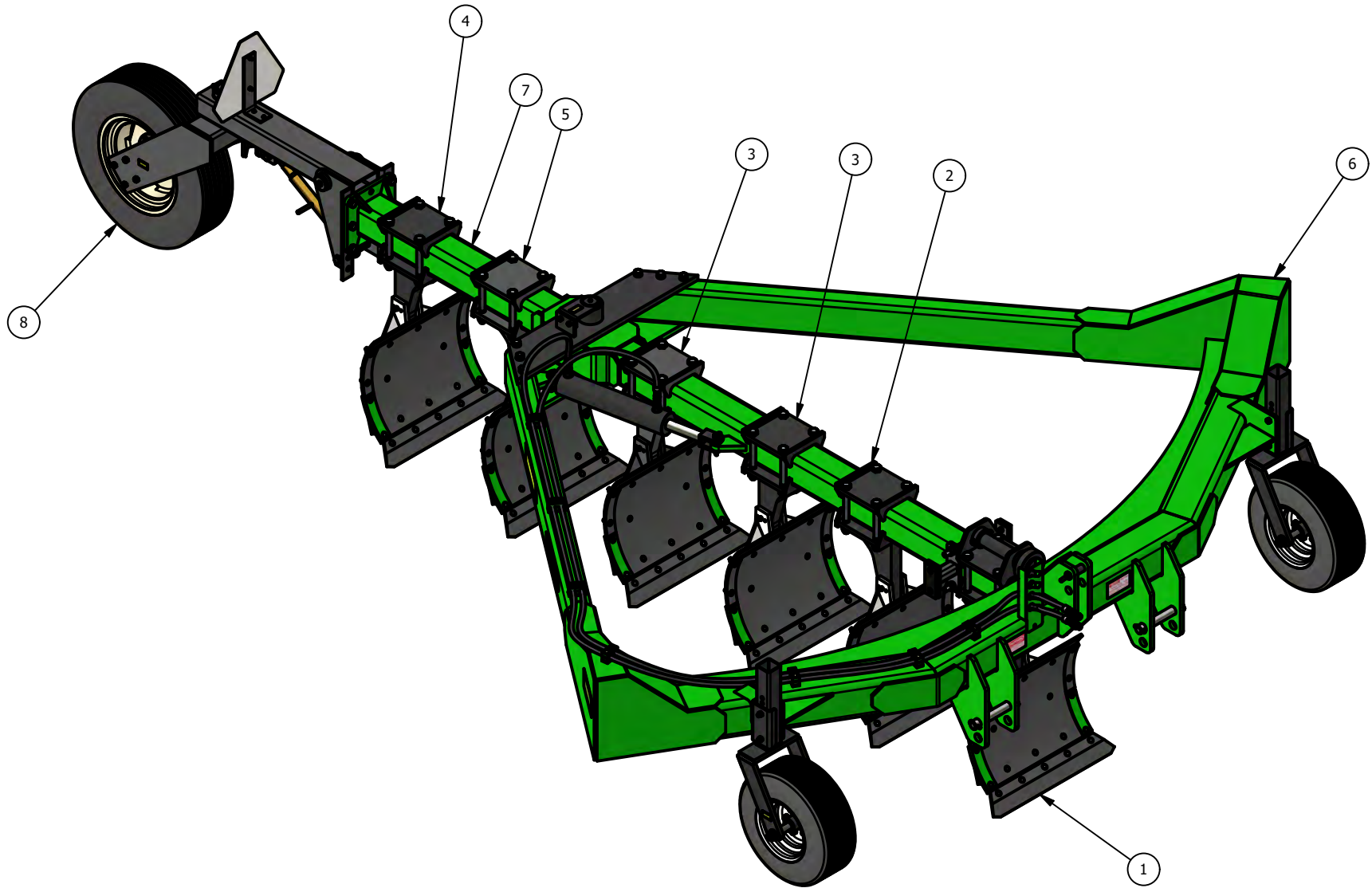

ITEM	ITEM QTY	PART NUMBER	DESCRIPTION
1	1	72-001-63	6300 SWITCH PLOW - FRONT BOTTOM KIT
2	1	72-002-63	6300 SWITCH PLOW - FORWARD INTERMEDIATE BOTTOM KIT
3	2	72-003-63	6300 SWITCH PLOW - REVERSE INTERMEDIATE BOTTOM KIT
4	1	72-004-63	6300 SWITCH PLOW - REVERSE REAR BOTTOM KIT
5	1	72-005-63	6300 SWITCH PLOW - FORWARD REAR BOTTOM KIT
6	1	83-001-63	6300 SWITCH PLOW - FRAME BUNDLE
7	1	83-003-63	6300 TOOL BAR
8	1	83-004-63	6300, 9400 SWITCH PLOW - REAR GAUGE WHEEL BUNDLE

72-001-63
6300 SWITCH PLOW - FRONT BOTTOM KIT

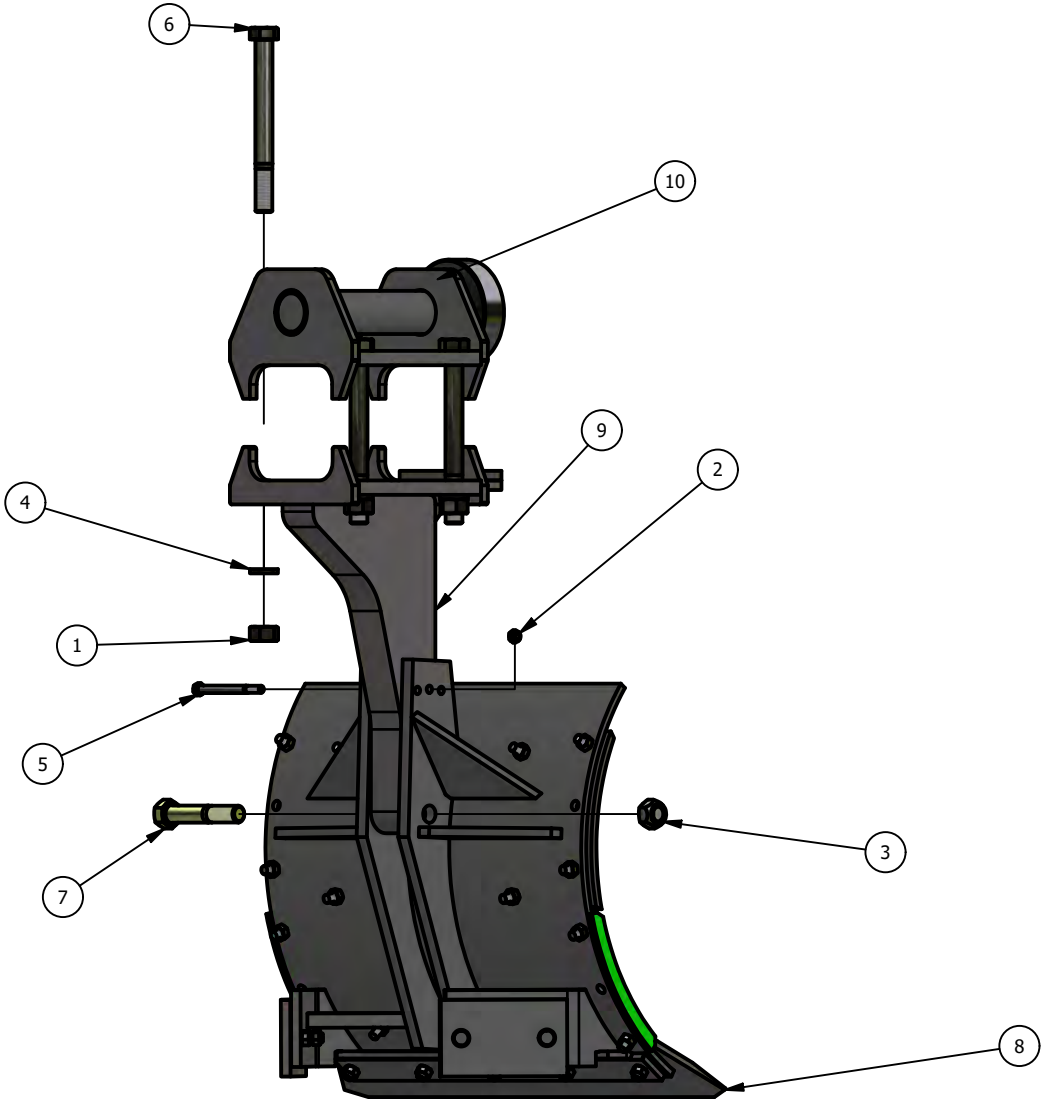

ITEM	ITEM QTY	PART NUMBER	DESCRIPTION
1	4	0812-2800	HEX NUT, 7/8
2	1	1412-1200	LOCK NUT, 3/8 STOVER ZP
3	1	1412-2800	LOCK NUT, 7/8 STOVER ZP
4	4	1602-2800	LOCK WASHER, 7/8 ZP
5	1	2816-1244	HEX HEAD BOLT, 3/8 X 4 1/2 GR5 ZP
6	4	2816-2890	HEX HEAD BOLT, 7/8 X 9 GR5 ZP
7	1	2818-2850	HEX HEAD BOLT, 7/8 X 5 GR 8
8	1	83-003-36	INTERMEDIATE MOLD BOARD W/ SHORT SLIDES - BUNDLE
9	1	84-1007-63	FRONT SHANK ASSEMBLY
10	1	84-214-36	TOOL BAR PIVOT ROLLER ASSEMBLY

72-002-63
6300 SWITCH PLOW - FORWARD INTERMEDIATE BOTTOM KIT

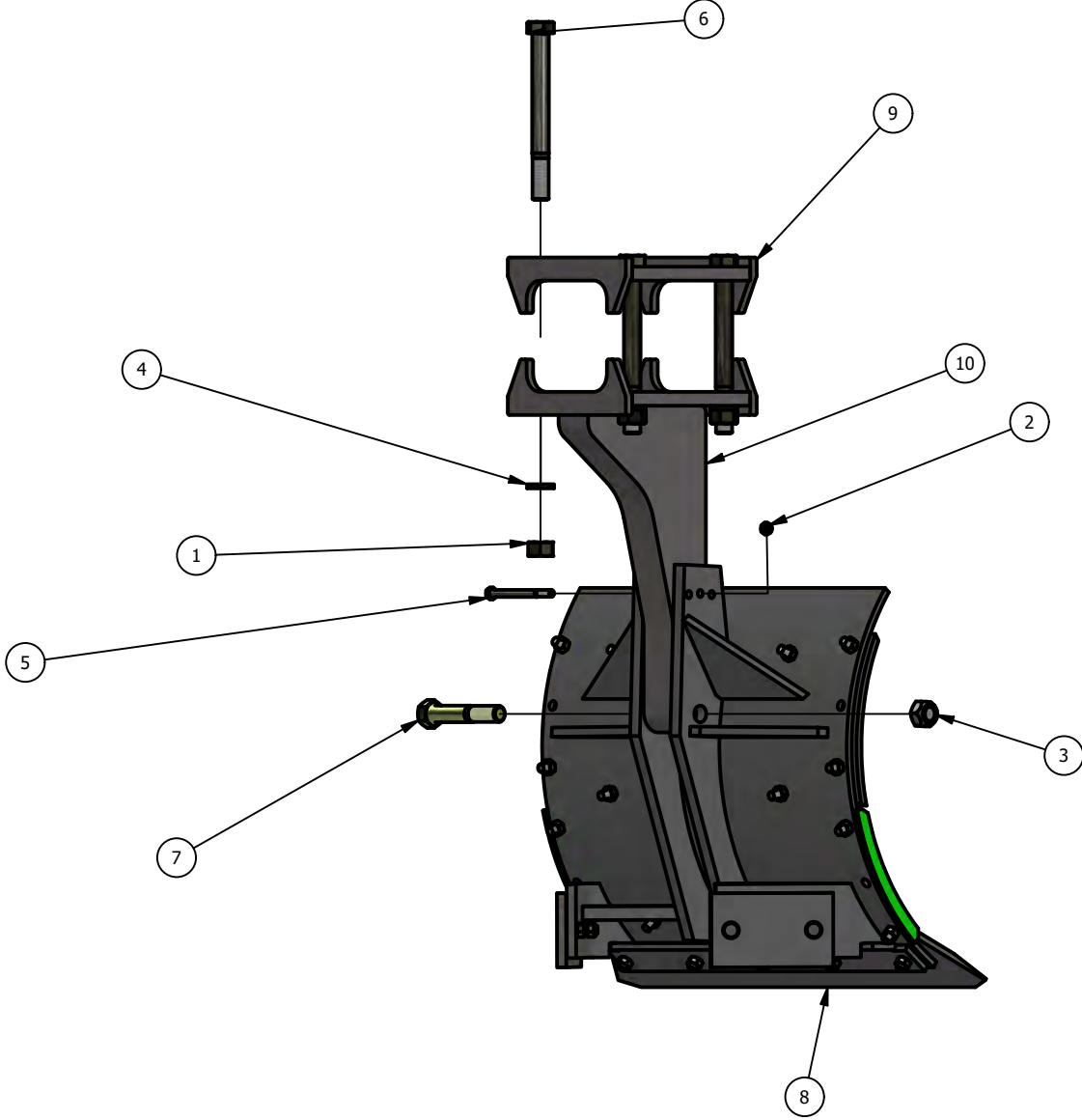

ITEM	ITEM QTY	PART NUMBER	DESCRIPTION
1	4	0812-2800	HEX NUT, 7/8
2	1	1412-1200	LOCK NUT, 3/8 STOVER ZP
3	1	1412-2800	LOCK NUT, 7/8 STOVER ZP
4	4	1602-2800	LOCK WASHER, 7/8 ZP
5	1	2816-1244	HEX HEAD BOLT, 3/8 X 4 1/2 GR5 ZP
6	4	2816-2890	HEX HEAD BOLT, 7/8 X 9 GR5 ZP
7	1	2818-2850	HEX HEAD BOLT, 7/8 X 5 GR 8
8	1	83-003-36	INTERMEDIATE MOLD BOARD W/ SHORT SLIDES - BUNDLE
9	1	85-017-36	TOP PLATE WELDMENT, 6" TOOL BAR
10	1	85-222-36	INTERMEDIATE SHANK WELDMENT

72-003-63
6300 SWITCH PLOW - REVERSE INTERMEDIATE BOTTOM KIT

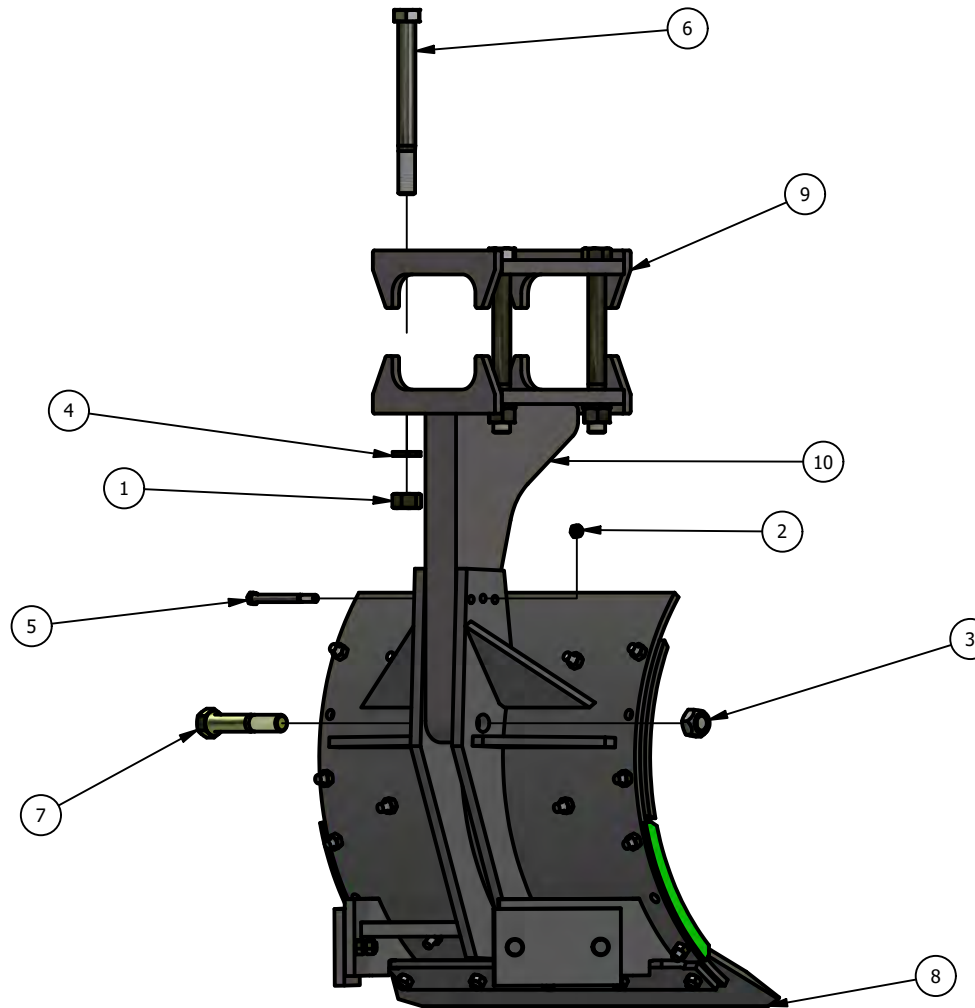

ITEM	ITEM QTY	PART NUMBER	DESCRIPTION
1	4	0812-2800	HEX NUT, 7/8
2	1	1412-1200	LOCK NUT, 3/8 STOVER ZP
3	1	1412-2800	LOCK NUT, 7/8 STOVER ZP
4	4	1602-2800	LOCK WASHER, 7/8 ZP
5	1	2816-1244	HEX HEAD BOLT, 3/8 X 4 1/2 GR5 ZP
6	4	2816-2890	HEX HEAD BOLT, 7/8 X 9 GR5 ZP
7	1	2818-2850	HEX HEAD BOLT, 7/8 X 5 GR 8
8	1	83-003-36	INTERMEDIATE MOLD BOARD W/ SHORT SLIDES - BUNDLE
9	1	85-017-36	TOP PLATE WELDMENT, 6" TOOL BAR
10	1	85-222-36	INTERMEDIATE SHANK WELDMENT

72-004-63
6300 SWITCH PLOW - REVERSE REAR BOTTOM KIT

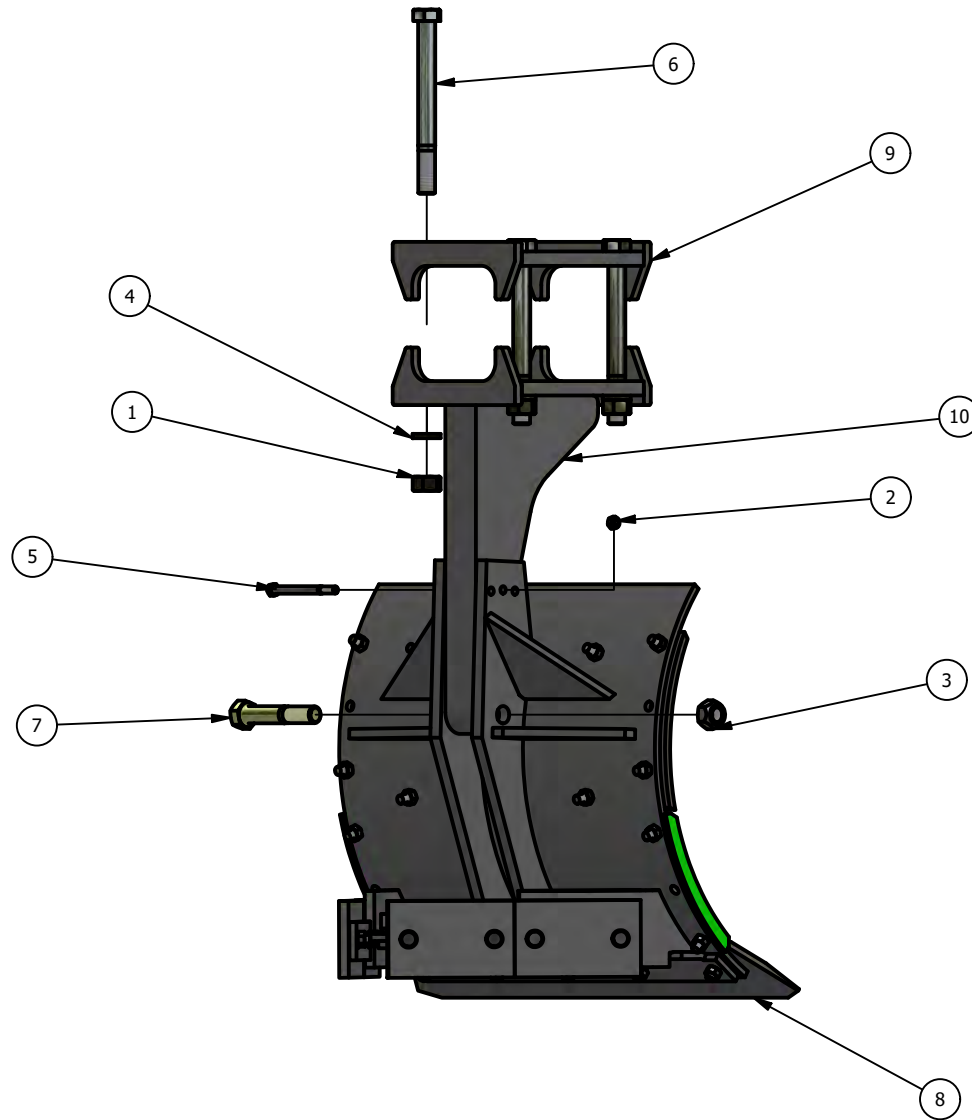

ITEM	ITEM QTY	PART NUMBER	DESCRIPTION
1	4	0812-2800	HEX NUT, 7/8
2	1	1412-1200	LOCK NUT, 3/8 STOVER ZP
3	1	1412-2800	LOCK NUT, 7/8 STOVER ZP
4	4	1602-2800	LOCK WASHER, 7/8 ZP
5	1	2816-1244	HEX HEAD BOLT, 3/8 X 4 1/2 GR5 ZP
6	4	2816-2890	HEX HEAD BOLT, 7/8 X 9 GR5 ZP
7	1	2818-2850	HEX HEAD BOLT, 7/8 X 5 GR 8
8	1	83-206-36	REAR MOLD BOARD W/ LONG SLIDES - BUNDLE
9	1	85-017-36	TOP PLATE WELDMENT, 6" TOOL BAR
10	1	85-222-36	INTERMEDIATE SHANK WELDMENT

72-005-63
6300 SWITCH PLOW - FORWARD REAR BOTTOM KIT

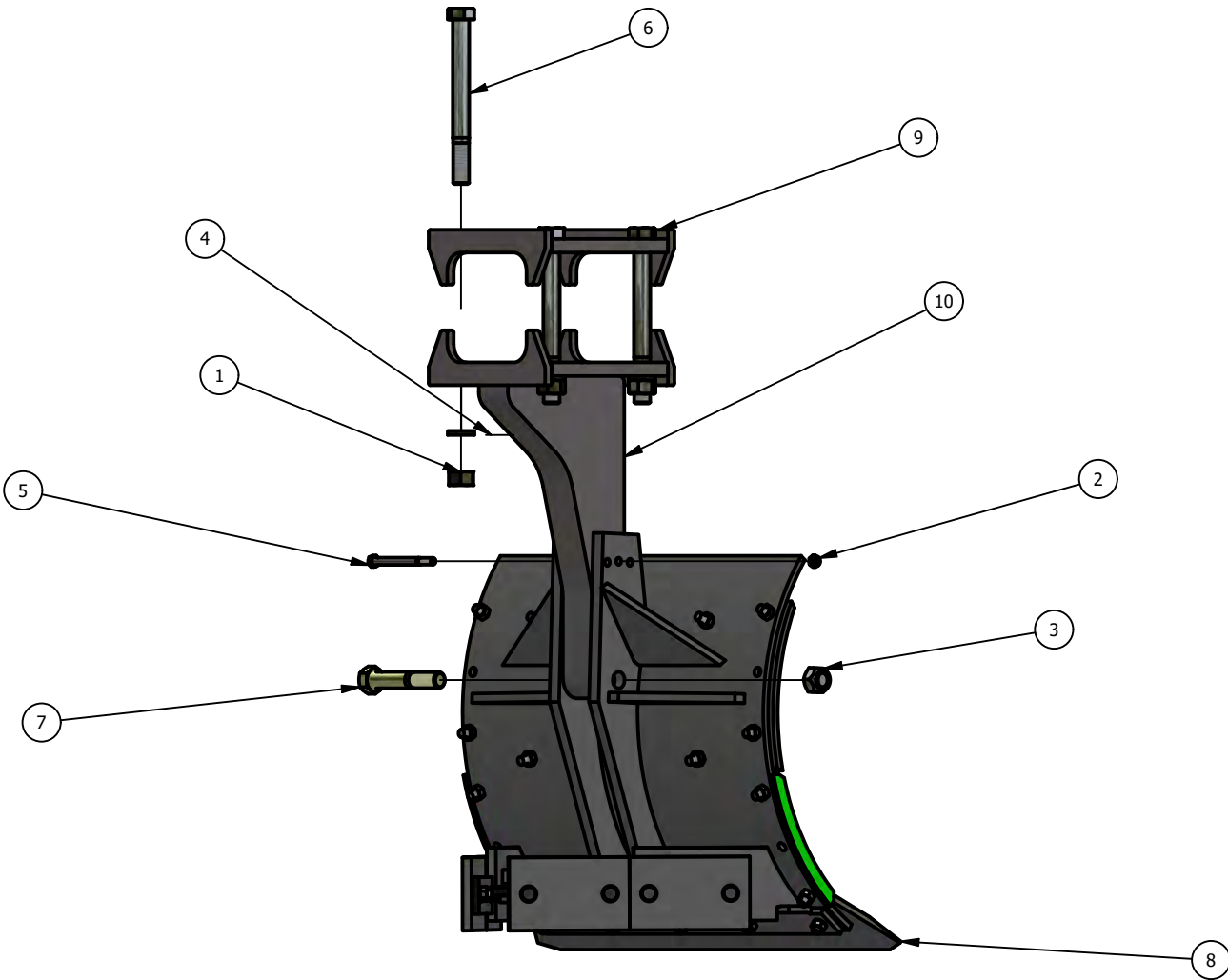

ITEM	ITEM QTY	PART NUMBER	DESCRIPTION
1	4	0812-2800	HEX NUT, 7/8
2	1	1412-1200	LOCK NUT, 3/8 STOVER ZP
3	1	1412-2800	LOCK NUT, 7/8 STOVER ZP
4	4	1602-2800	LOCK WASHER, 7/8 ZP
5	1	2816-1244	HEX HEAD BOLT, 3/8 X 4 1/2 GR5 ZP
6	4	2816-2890	HEX HEAD BOLT, 7/8 X 9 GR5 ZP
7	1	2818-2850	HEX HEAD BOLT, 7/8 X 5 GR 8
8	1	83-206-36	REAR MOLD BOARD W/ LONG SLIDES - BUNDLE
9	1	85-017-36	TOP PLATE WELDMENT, 6" TOOL BAR
10	1	85-222-36	INTERMEDIATE SHANK WELDMENT

83-001-63 6300 SWITCH PLOW - FRAME BUNDLE

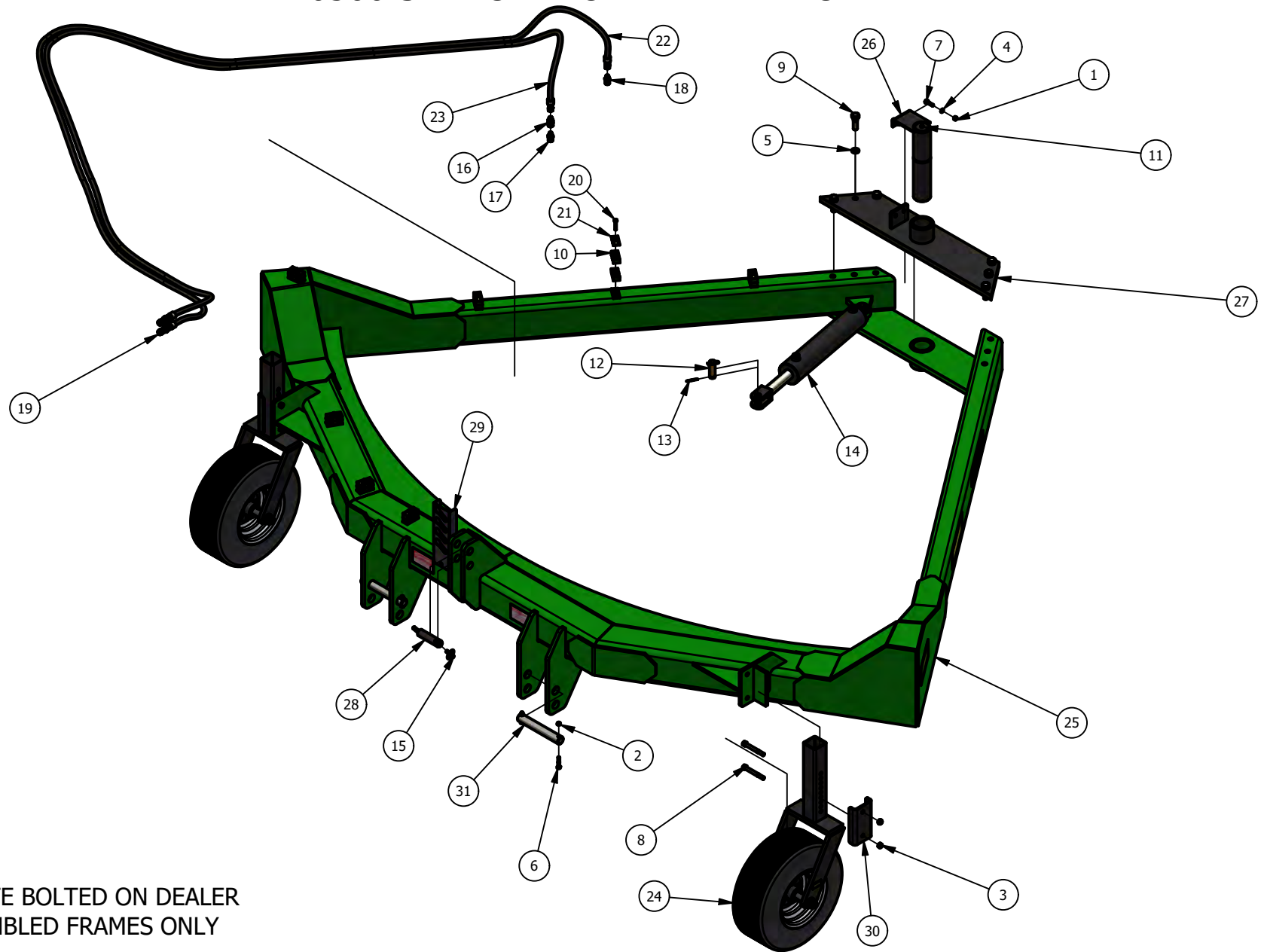

* - PLATE BOLTED ON DEALER
ASSEMBLED FRAMES ONLY

ITEM	ITEM QTY	PART NUMBER	DESCRIPTION
1	2	0812-1200	HEX NUT, 3/8
2	4	1412-1200	LOCK NUT, 3/8 STOVER ZP
3	4	1412-1600	LOCK NUT, 1/2 STOVER ZP
4	2	1602-1200	LOCK WASHER, 3/8 ZP
5	6	1602-2400	LOCK WASHER, 3/4 ZP
6	4	2814-1220	HEX HEAD BOLT, 3/8 X 2 GR 2 ZP
7	2	2816-1214	HEX HEAD BOLT, 3/8 X 1 1/2 GR5 ZP
8	4	2816-1644	HEX HEAD BOLT, 1/2 X 4 1/2 GR5 ZP
9	6	2816-2424	HEX HEAD BOLT, 3/4 X 2 1/2 GR5 ZP
10	14	79-002-36	TWIN HOSE CLAMP, 3/4"
11	1	79-005-38	1/8" NPT GREASE FITTING
12	2	79-006-06	CLEVIS PIN - 1" DIA. X 3-1/4"
13	4	79-043-06	1/8" HAIR PIN
14	1	79-047-36	HYDRAULIC CYLINDER 3.5" BORE X 16" STROKE
15	1	79-061-36	3/8" LYNCH PIN
16	1	79-205-28	3/8 MALE - FEMALE INLINE SWIVEL
17	1	79-213-28	1/2 MORB TO 3/8 ADAPTOR MJIC
18	1	79-213-28-WO	1/2 MORB TO 3/8 ADAPTOR MJIC WITH ORFICE
19	2	79-482-36	QUICK-CONNECT
20	7	79-496-50	TWIN CLAMP ASSEMBLY BOLT 3/8"X1-3/4" BRASS
21	7	79-497-50	TWIN CLAMP, LARGE TOP
22	1	79-497-63	3/8 DIA. X 228" HYDRAULIC HOSE
23	1	79-498-63	3/8 DIA. X 240" HYDRAULIC HOSE
24	2	84-003-63	FRONT GAUGE WHEEL ASSEMBLY
25	1	85-001-63	6300 MAIN FRAME WELDMENT
26	1	85-006-63	6300 PIVOT PIN WELDMENT
27	1	85-011-63	BOLT-ON UPPER PIVOT PLATE WELDMENT
28	1	85-029-36	UPPER HITCH PIN WELDMENT
29	1	93-095-55	HYDRAULIC HOSE END HOLDER
30	2	93-1014-63	FRONT GAUGE WHEEL CLAMP PLATE
31	2	96-015-06	LOWER HITCH PIN

83-003-63
6300 TOOL BAR

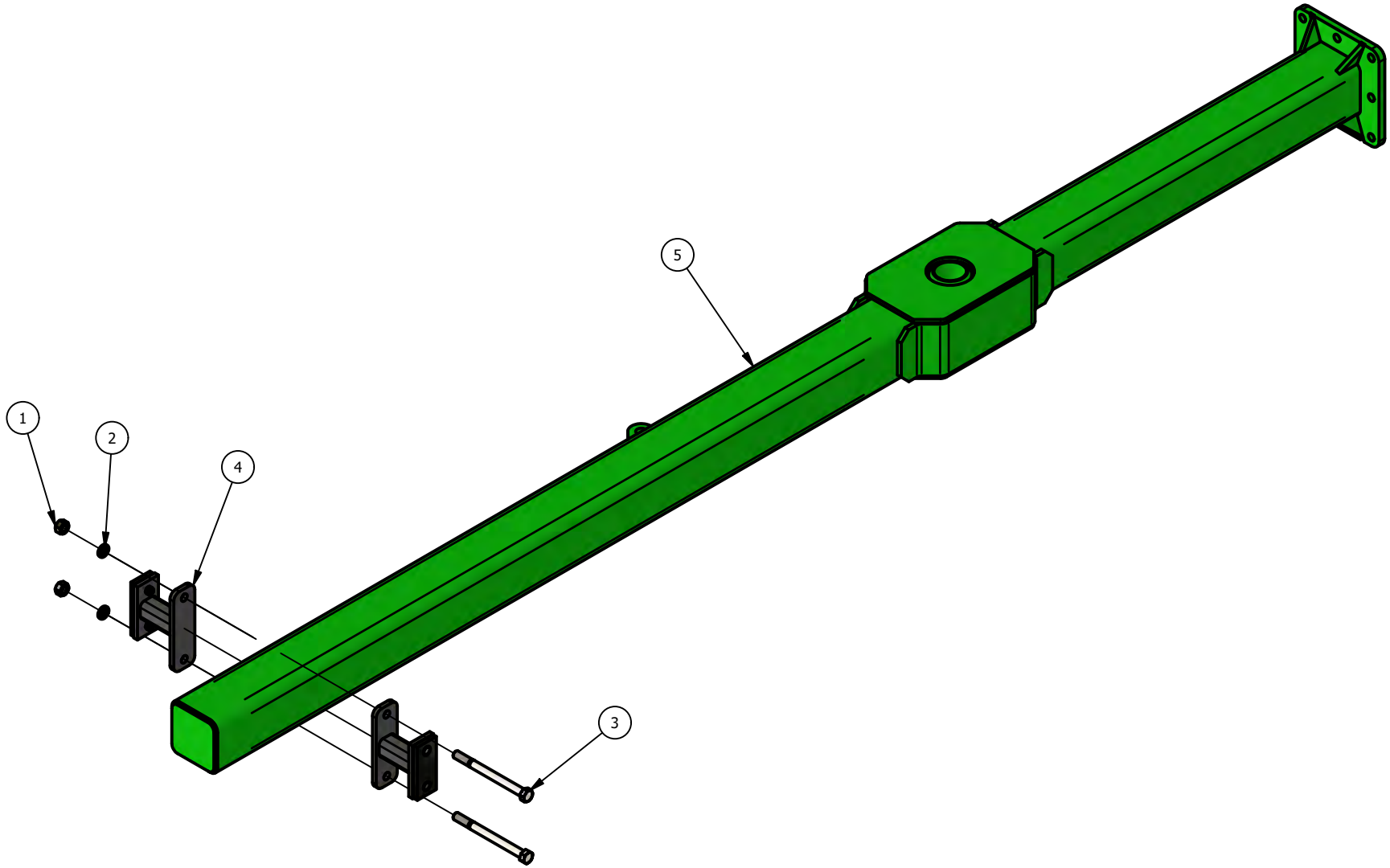

ITEM	ITEM QTY	PART NUMBER	DESCRIPTION
1	2	0812-2400	HEX NUT, 3/4
2	2	1602-2400	LOCK WASHER, 3/4 ZP
3	2	2816-2490	HEX HEAD BOLT, 3/4 X 9 GR5 ZP
4	2	84-1006-63	TOOL BAR STOP ASSEMBLY
5	1	85-005-63	6300 TOOL BAR WELDMENT 6-BOTTOM

83-003-36 INTERMEDIATE MOLD BOARD W/ SHORT SLIDES - BUNDLE

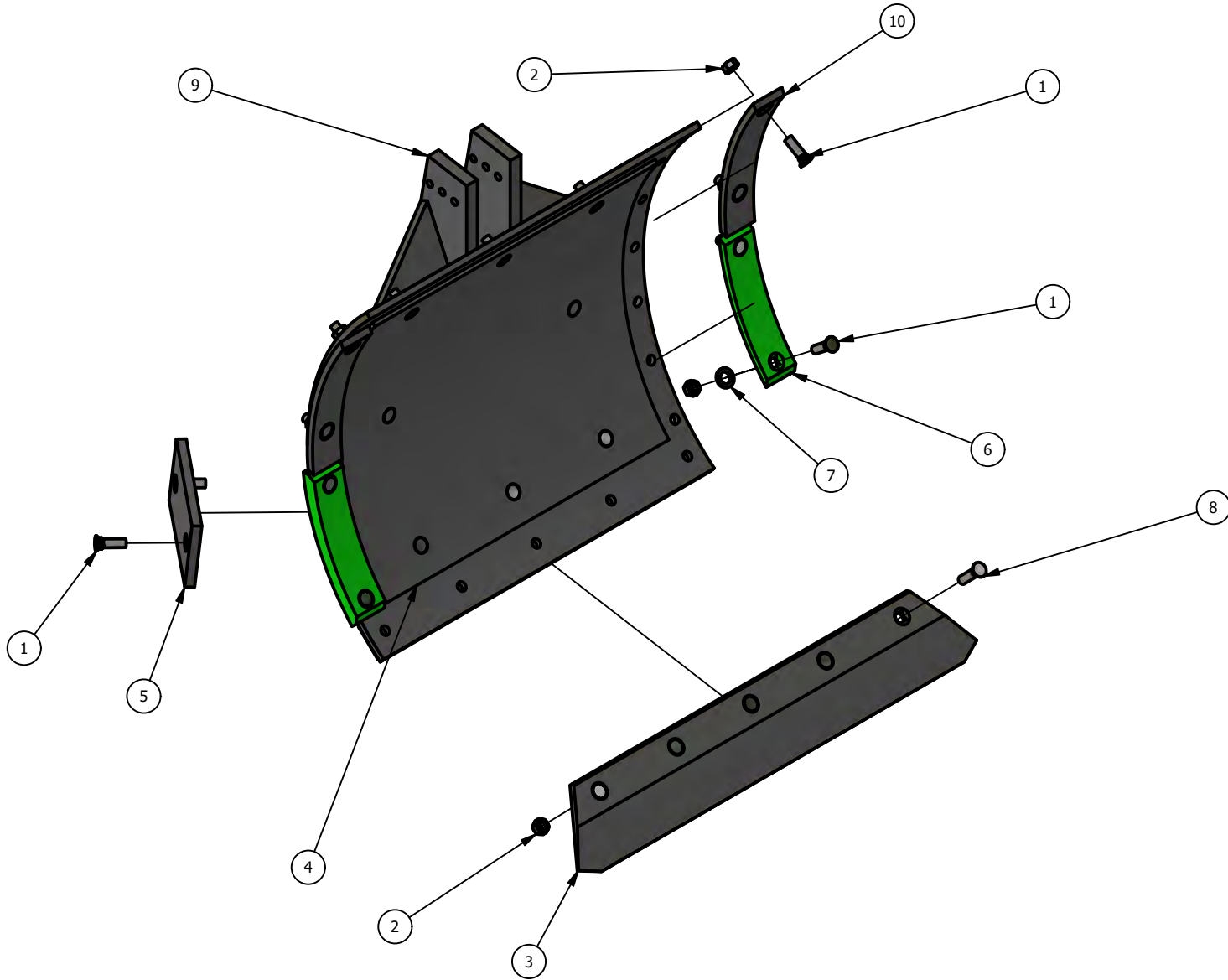

ITEM	ITEM QTY	PART NUMBER	DESCRIPTION
1	20	0315-1414	PLOW BOLT, 7/16x1-1/2 Gr5
2	25	0812-1400	HEX NUT, 7/16
3	1	79-006-36	PLOW SHARE - HEAT TREATED
4	1	79-201-36	1/4" UHMW PLASTIC WING
5	2	79-204-36	SMALL SLIDE - MULTI LIFE
6	2	79-208-36	LOWER WEAR SHIN
7	4	79-218-36	OICW - RUBBER WASHER
8	5	79-483-36	PLOW BOLT, 7/16 x 1 3/4, CLIP HEAD
9	1	85-006-36	MOLD BOARD WELDMENT
10	2	98-207-36	UPPER WEAR SHIN

83-206-36
REAR MOLD BOARD W/ LONG SLIDES - BUNDLE

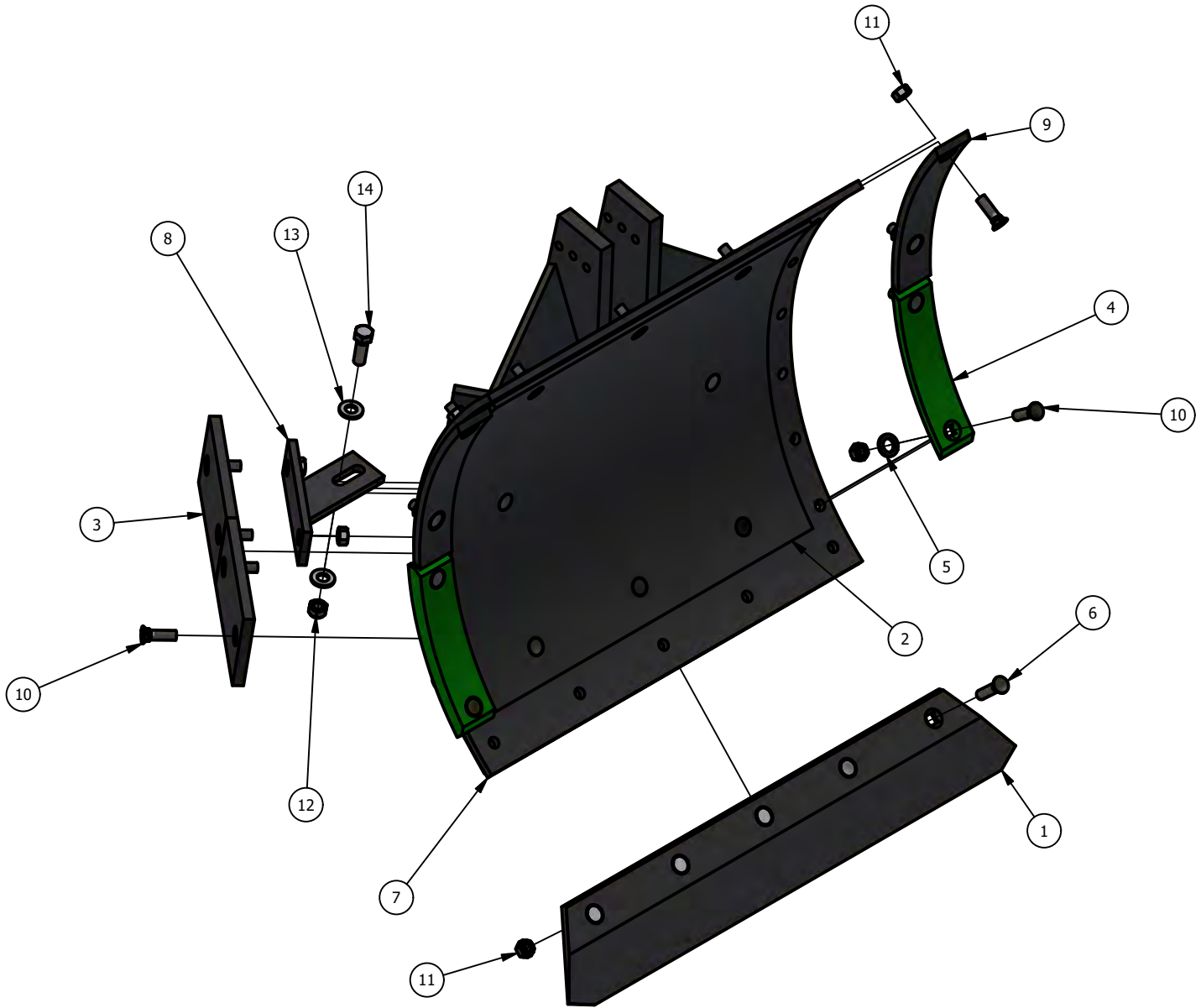

ITEM	ITEM QTY	PART NUMBER	DESCRIPTION
1	1	79-006-36	PLOW SHARE - HEAT TREATED
2	1	79-201-36	1/4" UHMW PLASTIC WING
3	2	79-205-36	LONG SLIDE - MULTI-LIFE
4	2	79-208-36	LOWER WEAR SHIN
5	4	79-218-36	OICW - RUBBER WASHER
6	5	79-483-36	PLOW BOLT, 7/16 x 1 3/4, CLIP HEAD
7	1	85-006-36	MOLD BOARD WELDMENT
8	2	85-217-36	LONG SLIDE BRACE WELDMENT
9	2	98-207-36	UPPER WEAR SHIN
10	24	0315-1414	PLOW BOLT, 7/16x1-1/2 Gr5
11	29	0812-1400	HEX NUT, 7/16
12	1	1412-1600	LOCK NUT, 1/2 STOVER ZP
13	2	1702-1600	FLAT WASHER, 1/2 ZP
14	1	2816-1614	HEX HEAD BOLT, 1/2 X 1 1/2 GR5 ZP

83-004-63
6300, 9400 SWITCH PLOW - REAR GAUGE WHEEL BUNDLE

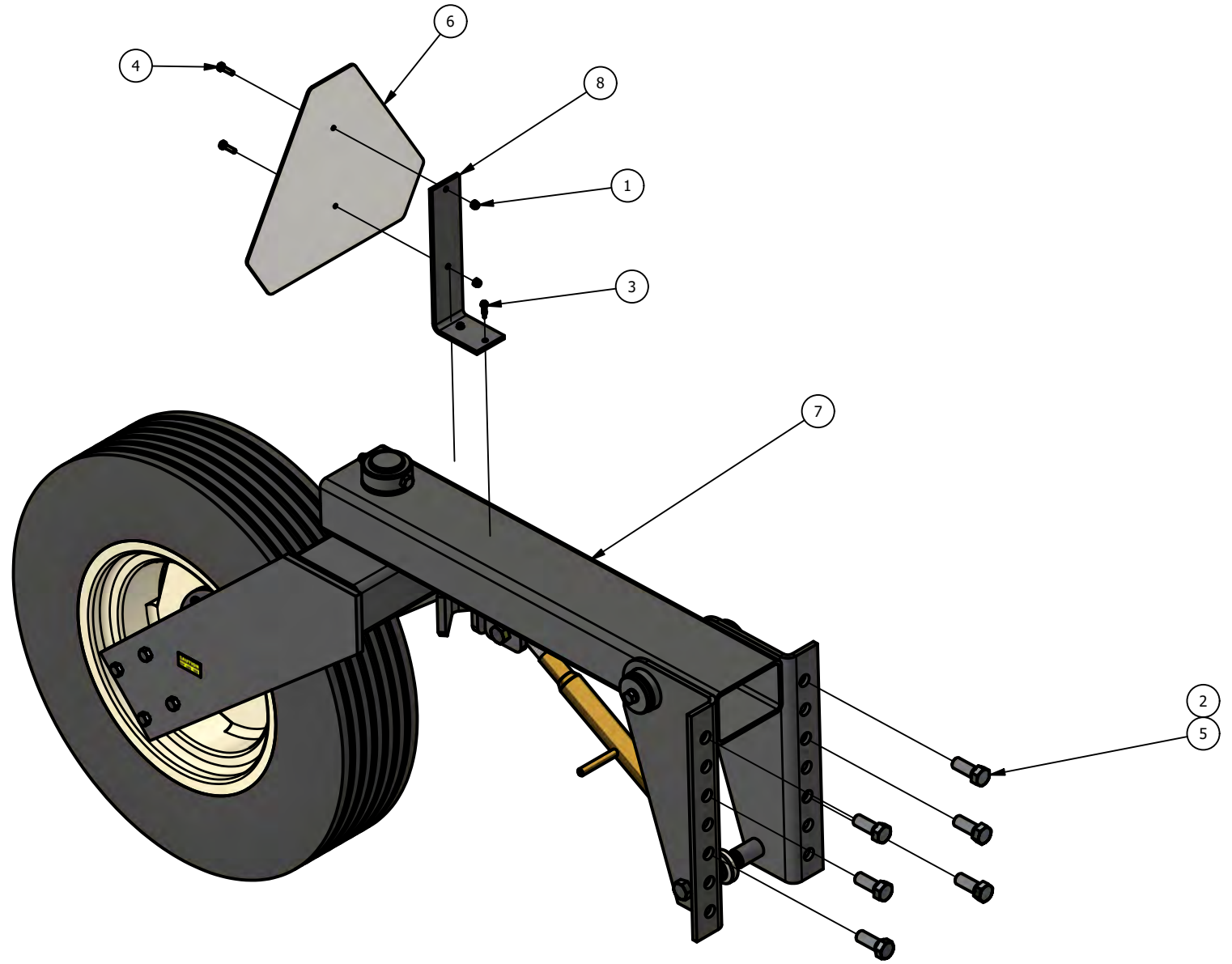

ITEM	ITEM QTY	PART NUMBER	DESCRIPTION
1	2	0912-0800	LOCK NUT, 1/4 NYLOCK ZP
2	6	1412-2400	LOCK NUT, 3/4 STOVER ZP
3	2	1913-1010	SELF TAP SCREW, 12X1
4	2	2816-0810	HEX HEAD BOLT, 1/4 X 1 GR5 ZP
5	6	2816-2420	HEX HEAD BOLT, 3/4 X 2 GR5 ZP
6	1	79-001-01M	SLOW MOVING VEHICLE SIGN
7	1	84-1000-63	REAR GAUGE WHEEL MAIN ASSEMBLY
8	1	93-1020-63	SMV BRACKET

84-214-36 TOOL BAR PIVOT ROLLER ASSEMBLY

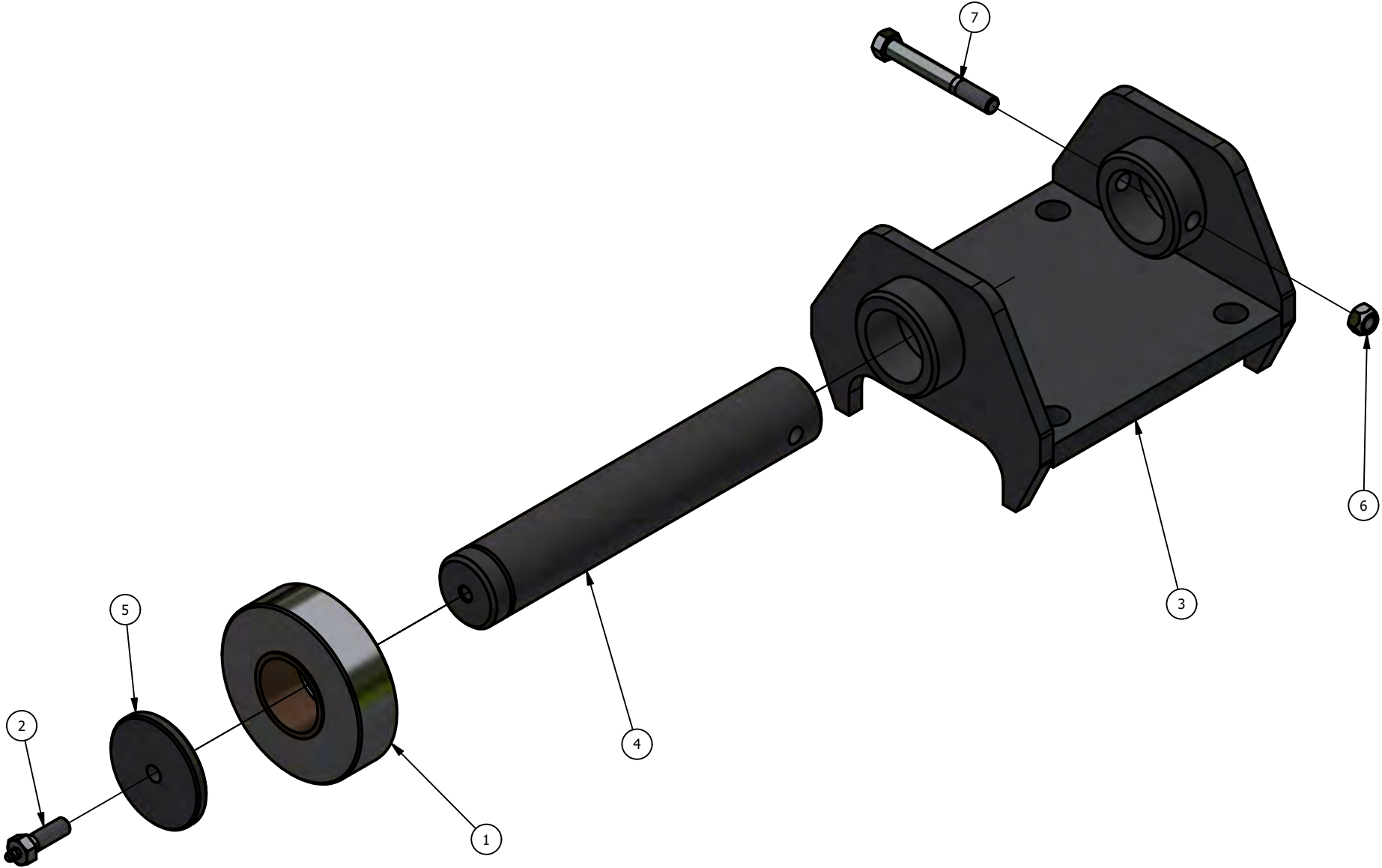



ITEM	ITEM QTY	PART NUMBER	DESCRIPTION
1	1	84-213-36	ROLLER ASSEMBLY
2	1	84-1015-63	GREASE BOLT ASSEMBLY
3	1	85-221-36	PIVOT BAR ROLLER MOUNTING PLATE WELDMENT
4	1	96-204-36	ROLLER SHAFT
5	1	96-205-36	PIVOT ROLLER PIN CAP
6	1	1412-1600	LOCK NUT, 1/2 STOVER ZP
7	1	2816-1640	HEX HEAD BOLT, 1/2 X 4 GR5 ZP

84-1000-63 REAR GAUGE WHEEL MAIN ASSEMBLY

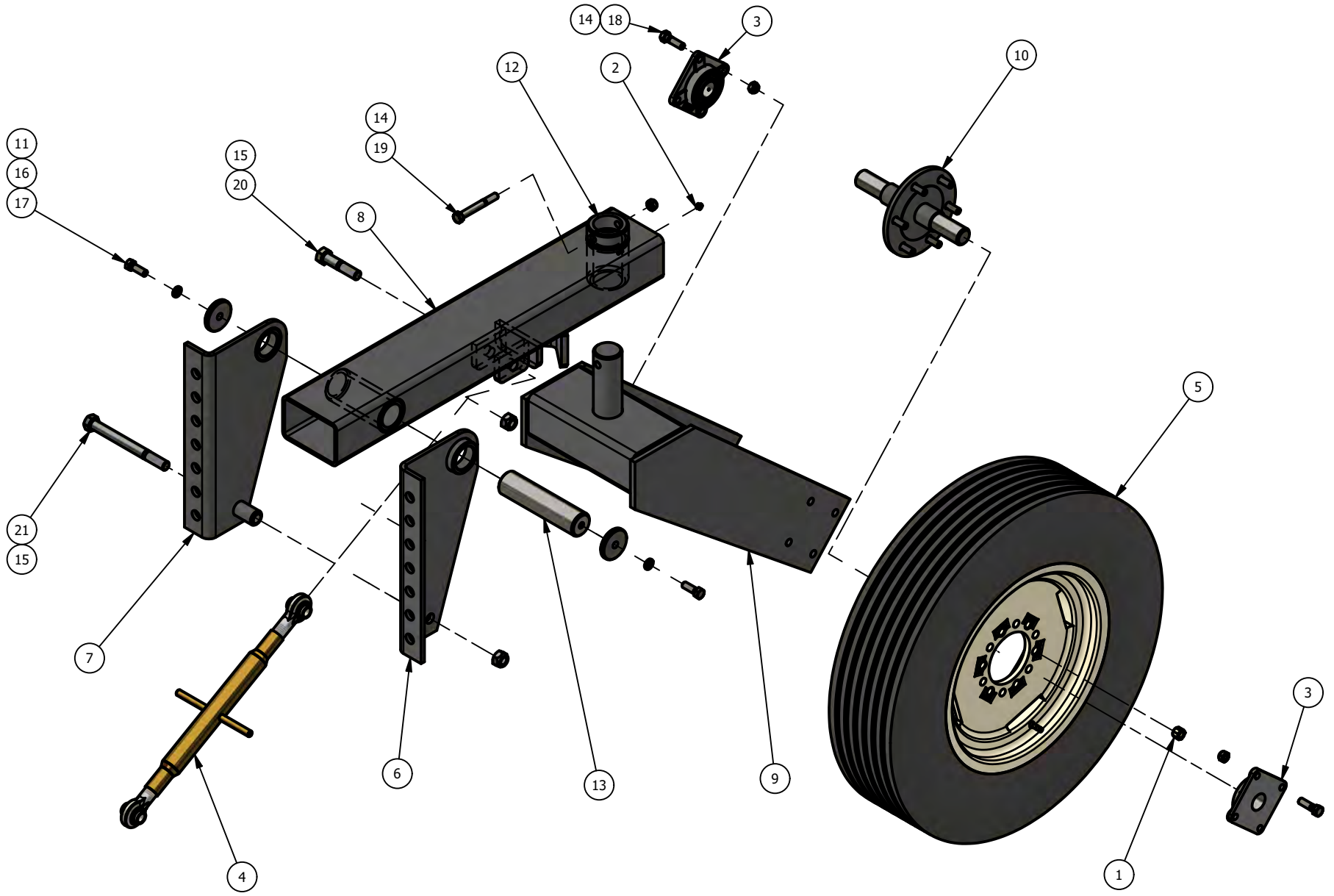

ITEM	ITEM QTY	PART NUMBER	DESCRIPTION
1	6	77-024-88	1/2" 90° NUT, SAE GRADE 8
2	1	79-005-38	1/8" NPT GREASE FITTING
3	2	79-277-06	4 HOLE FLANGE BEARING, 1-7/16" BORE - PICTORIAL
4	1	79-297-82	ADJUSTABLE TOP LINK
5	1	84-1001-63	REAR GAUGE WHEEL - TIRE, WHEEL & VALVE STEM ASSEMBLY
6	1	85-1001-63	REAR GAUGE WHEEL MOUNT - LH WELDMENT
7	1	85-1002-63	REAR GAUGE WHEEL MOUNT - RH WELDMENT
8	1	85-1003-63	REAR GAUGE WHEEL ARM WELDMENT
9	1	85-1004-63	REAR GAUGE WHEEL YOKE WELDMENT
10	1	85-1005-63	GAUGE WHEEL HUB & AXLE WELDMENT
11	2	93-1006-63	GAUGE WHEEL ARM PIN CAP
12	1	94-1002-63	GAUGE WHEEL & PIVOT ROLLER RETAINER BUSHING
13	1	96-1000-63	GAUGE WHEEL ARM PIN
14	9	1412-1600	LOCK NUT, 1/2 STOVER ZP
15	2	1412-2400	LOCK NUT, 3/4 STOVER ZP
16	2	1602-1600	LOCK WASHER, 1/2 ZP
17	2	2816-1614	HEX HEAD BOLT, 1/2 X 1 1/2 GR5 ZP
18	8	2816-1616	HEX HEAD BOLT, 1/2 X 1 3/4 GR5 ZP
19	1	2816-1640	HEX HEAD BOLT, 1/2 X 4 GR5 ZP
20	1	2816-2434	HEX HEAD BOLT, 3/4 X 3 1/2 GR5 ZP
21	1	2816-2480	HEX HEAD BOLT, 3/4 X 8 GR5 ZP

84-003-63 FRONT GAUGE WHEEL ASSEMBLY

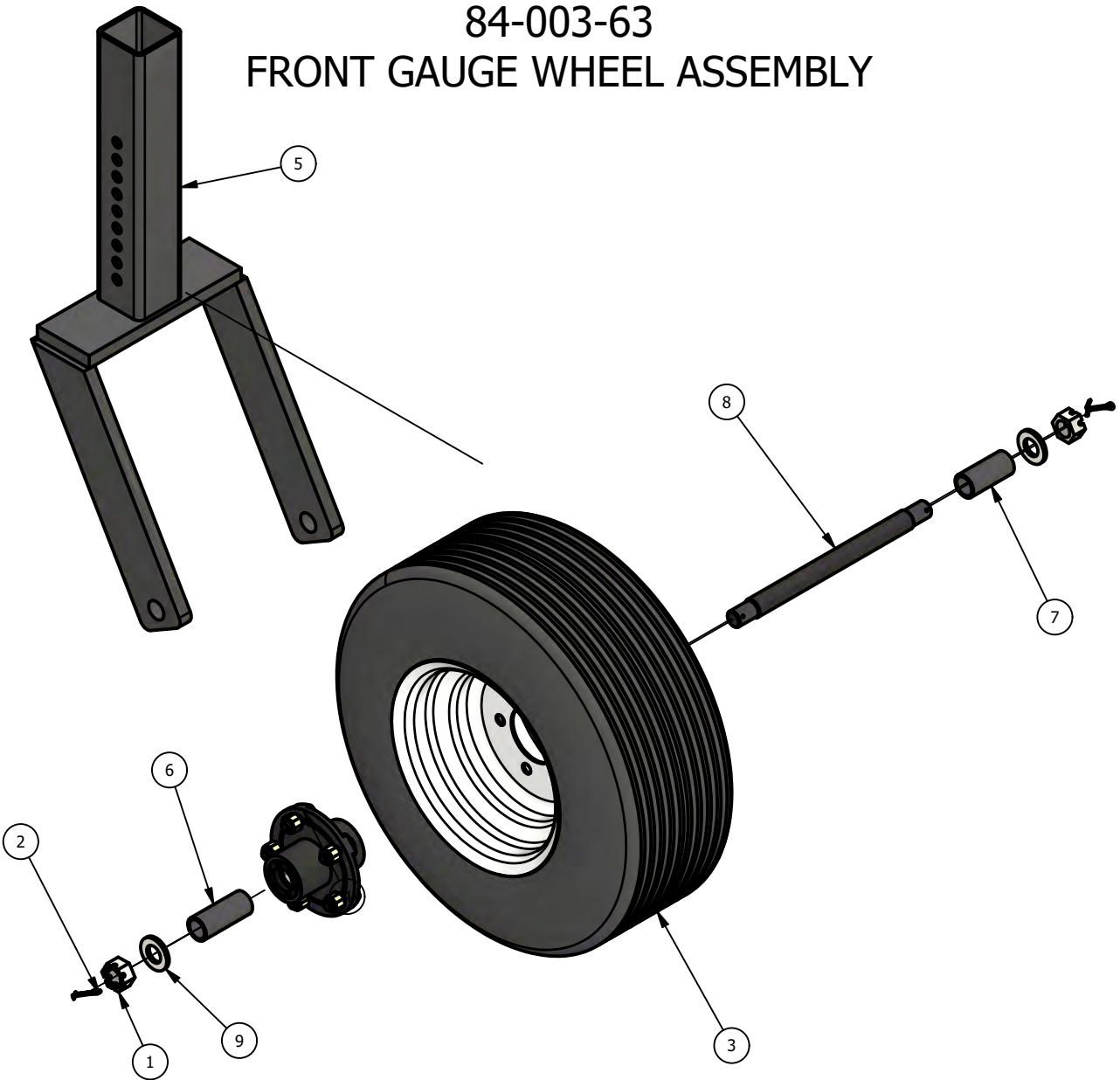

ITEM	ITEM QTY	PART NUMBER	DESCRIPTION
1	2	77-004-02	SPINDLE NUT - PICTORIAL
2	2	77-011-02	COTTER PIN - PICTORIAL
3	1	84-001-36	WHEEL, TIRE & VALVE STEM ASSEMBLY
4	1	84-1014-63	HUB ASSEMBLY, 5 BOLT GW
5	1	85-009-63	FRONT GAUGE WHEEL YOKE WELDMENT
6	1	94-1011-63	OUTER SPINDLE SHAFT BUSHING
7	1	94-1012-63	INNER SPINDLE SHAFT BUSHING
8	1	96-006-36	SPINDLE SHAFT - FRONT GAUGE WHEEL
9	2	1702-2800	FLAT WASHER, 7/8 ZP

84-1006-63 TOOL BAR STOP ASSEMBLY

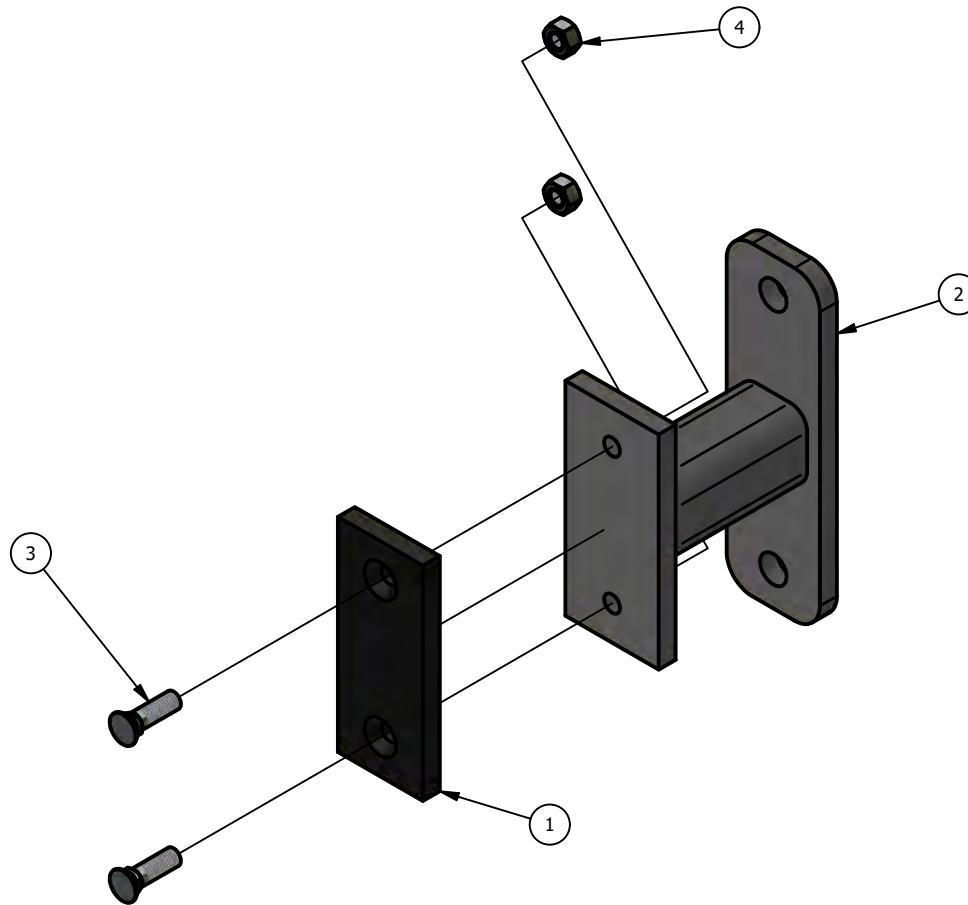



ITEM	ITEM QTY	PART NUMBER	DESCRIPTION
1	1	79-1001-63	1/2" UHMW - BUMPER PAD
2	1	85-012-63	TOOL BAR STOP WELDMENT
3	2	0315-1414	PLOW BOLT, 7/16x1-1/2 Gr5
4	2	0812-1400	HEX NUT, 7/16

84-1007-63
FRONT SHANK ASSEMBLY

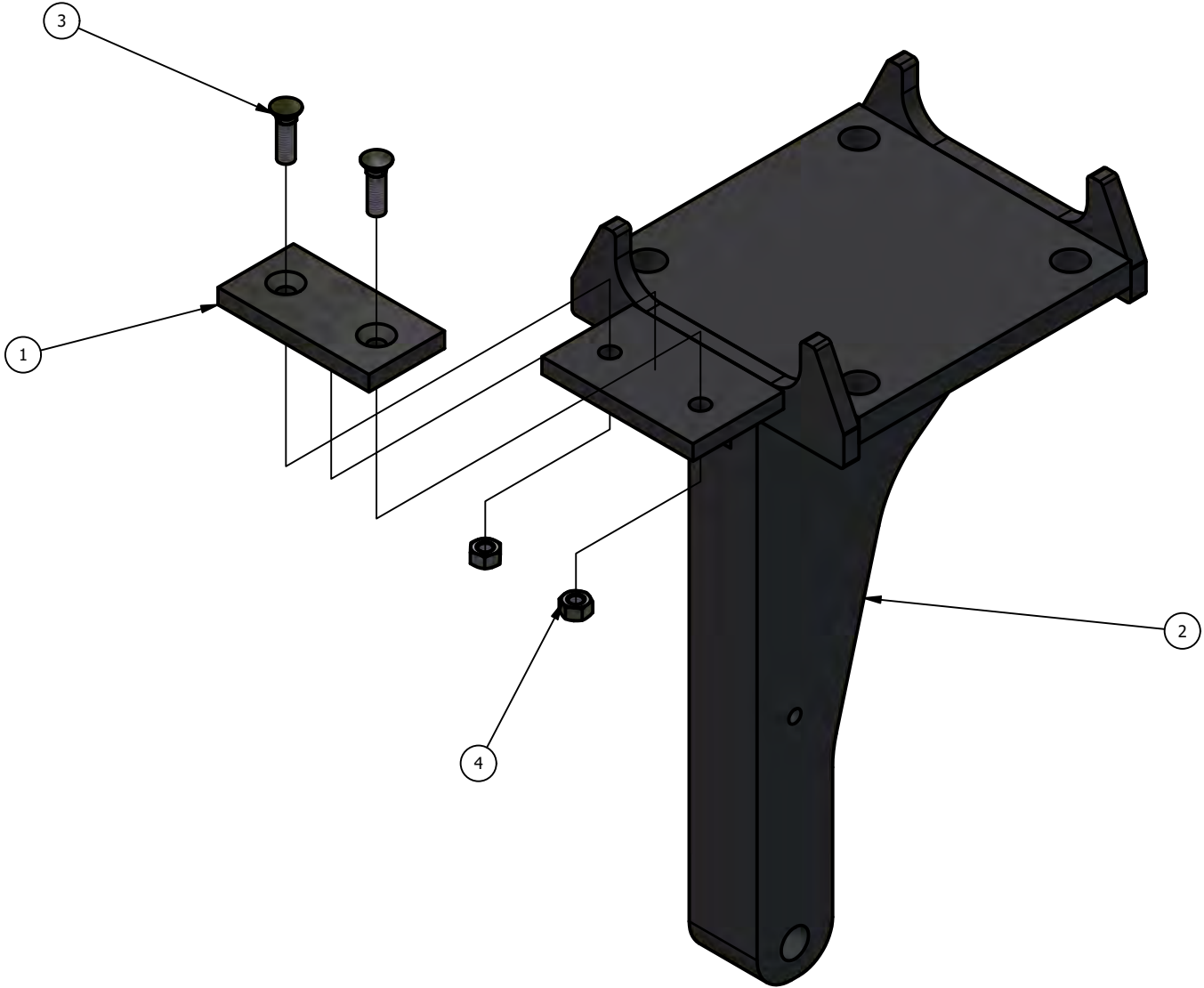



ITEM	ITEM QTY	PART NUMBER	DESCRIPTION
1	1	79-1002-63	1/2" UHMW - SLIDE WEAR PAD FOR FRONT SHANK WELDMENT
2	1	85-224-36	FRONT SHANK WELDMENT
3	2	0315-1414	PLOW BOLT, 7/16x1-1/2 Gr5
4	2	0812-1400	HEX NUT, 7/16

84-1014-63
HUB ASSEMBLY, 5 BOLT GW

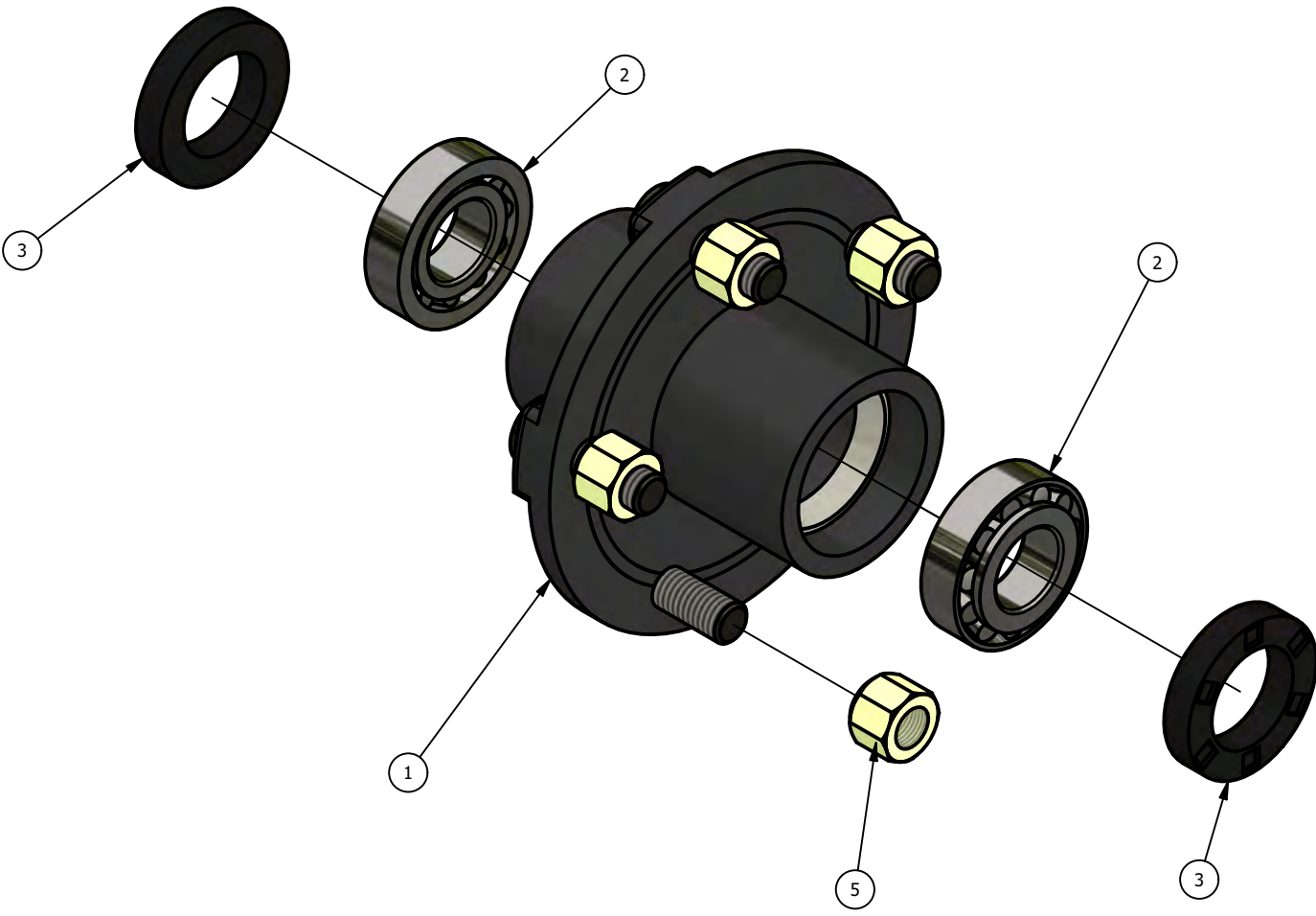

ITEM	ITEM QTY	PART NUMBER	DESCRIPTION
1	1	77-001-36	5 BOLT HUB W/RACES - PICTORIAL
2	2	77-002-36	TAPERED ROLLER BEARING - PICTORIAL
3	2	77-003-36	HUB GREASE SEAL - PICTORIAL
4	5	77-009-36	PRESS FIT LUG STUD, 1/2 X 1-1/4
5	5	77-024-88	1/2" 90° NUT, SAE GRADE 8

79-047-36
HYDRAULIC CYLINDER 3.5" BORE X 16" STROKE

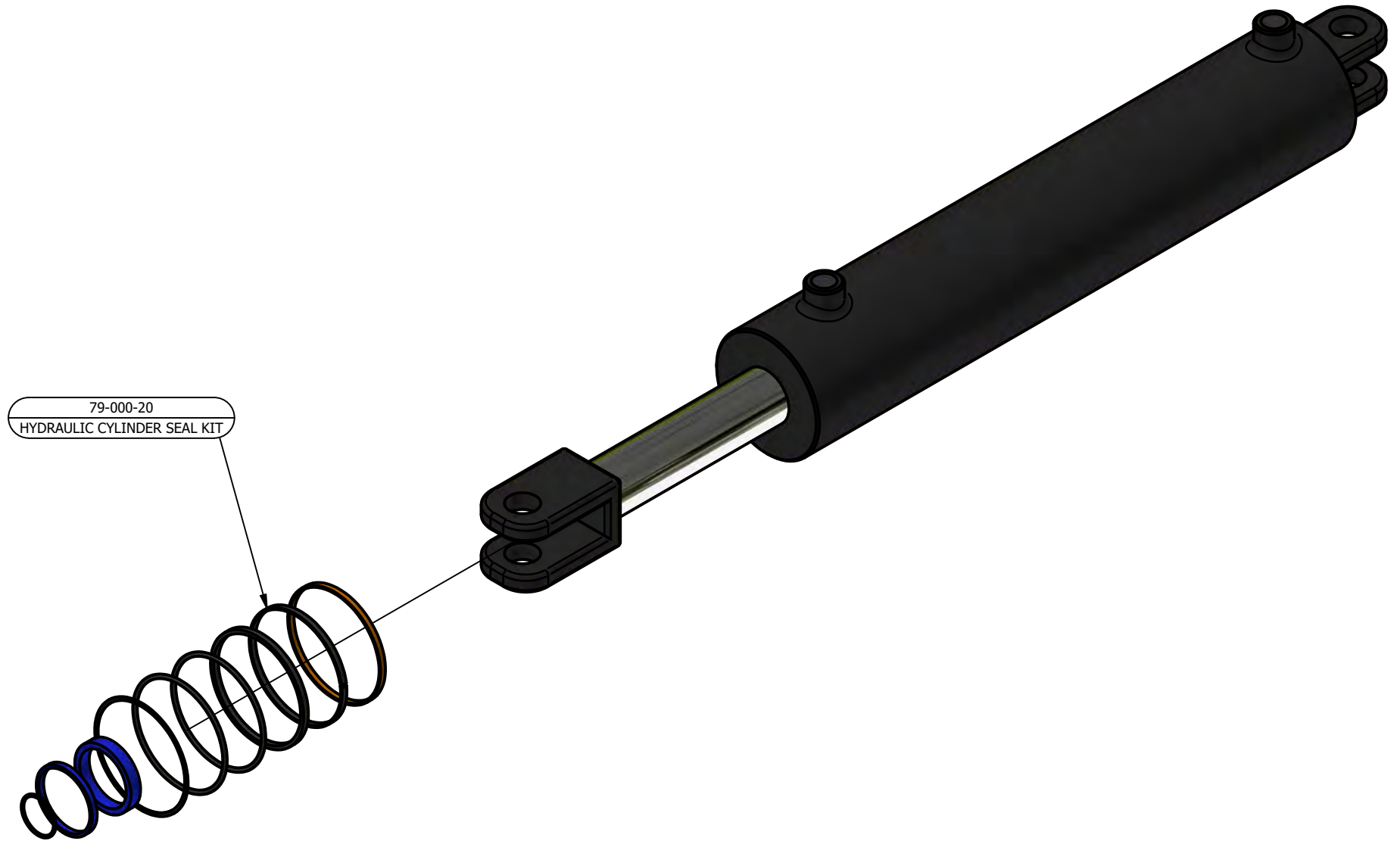

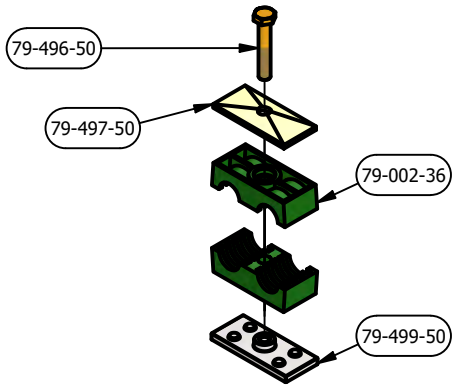

79-001-36
TWIN HOSE CLAMP ASSEMBLY 3/4"



79-006-36
PLOW SHARE - HEAT TREATED



79-061-36
3/8" LYNCH PIN



79-201-36
1/4" UHMW PLASTIC WING

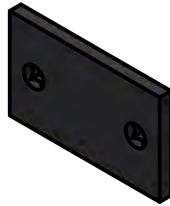

79-204-36
SMALL SLIDE - MULTI LIFE

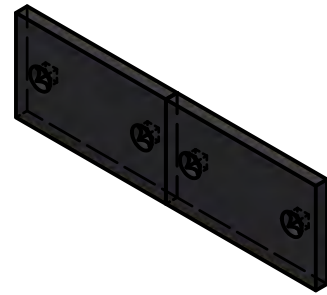

79-205-36
LONG SLIDE - MULTI-LIFE



84-1010-63
6300 PIVOT PIN ASSEMBLY

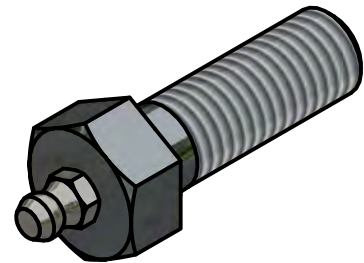

84-1015-63
GREASE BOLT ASSEMBLY

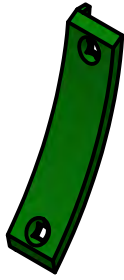

79-208-36
LOWER WEAR SHIN



98-207-36
UPPER WEAR SHIN



79-482-36
QUICK-CONNECT



84-001-36
WHEEL, TIRE & VALVE STEM ASSEMBLY

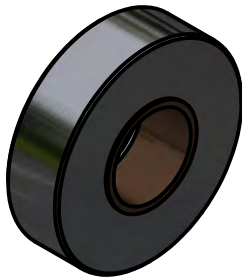

84-213-36
ROLLER ASSEMBLY



79-1001-63
1/2" UHMW - BUMPER PAD

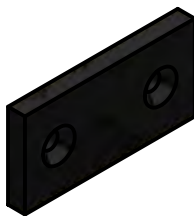

79-1002-63
SLIDE WEAR PAD FOR FRONT SHANK

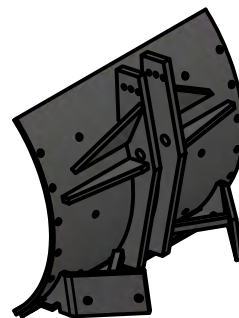

85-006-36
MOLD BOARD WELDMENT



85-029-36
UPPER HITCH PIN WELDMENT

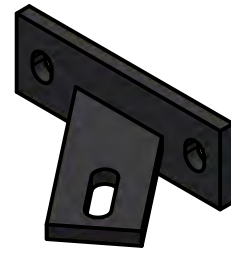

85-217-36
LONG SLIDE BRACE WELDMENT



85-222-36
INTERMEDIATE SHANK WELDMENT

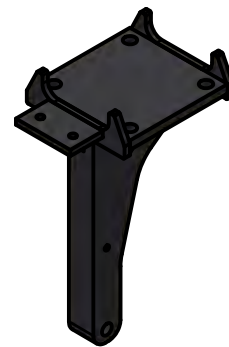

85-224-36
FRONT SHANK WELDMENT



93-1014-63
FRONT GAUGE WHEEL CLAMP PLATE



93-1006-63
GAUGE WHEEL ARM PIN CAP

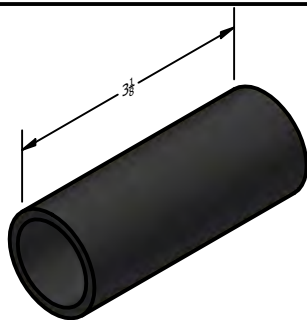

94-1011-63
OUTER SPINDLE SHAFT BUSHING

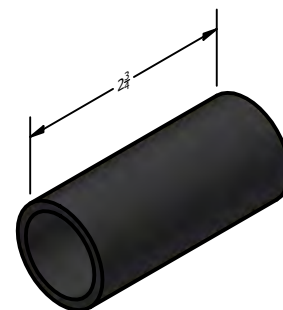

94-1012-63
INNER SPINDLE SHAFT BUSHING

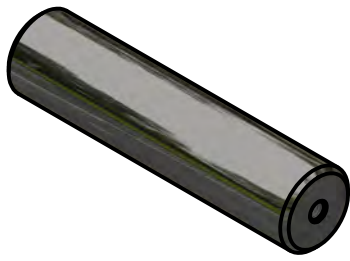

96-1000-63
GAUGE WHEEL ARM PIN



96-015-36
LOWER HITCH PIN



96-006-36
SPINDLE SHAFT - FRONT GAUGE WHEEL



79-205-28
3/8 MALE - FEMALE INLINE SWIVEL

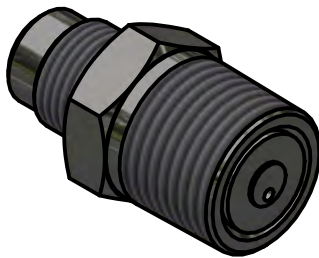

79-213-28-WO
1/2 MORB TO 3/8 ADAPTOR MJIC WITH ORFICE



79-213-28
1/2 MORB TO 3/8 ADAPTOR MJIC



79-297-82
ADJUSTABLE TOP LINK

HYDRAULIC HOSE ASSEMBLIES

RETRACT (228") - 79-497-63

EXTEND (240") - 79-498-63